

Amerex Fire Suppression Systems

Because Operators and the Environment are NOT Disposable



Quality is Behind the Diamond.



Quality is Behind the Diamond.

Diamonds have long been a symbol for quality. At Amerex we pride ourselves on the quality of the products we bring to the marketplace. We have to. We make products that are the keystone in the protection of life and property. Through the years Amerex has earned its reputation for quality. It's part of the reason we chose the diamond for a logo.



Tough Protection for a Rugged Environment

Fire Protection for Landfill vehicles present a difficult challenge. The machines collect combustible Class A materials in the engine compartment which can absorb flammable liquids and ignite. If the fire is not detected and suppressed rapidly it can spread throughout the machine quickly and ignite the surrounding combustible materials on the Landfill or Transfer station. Amerex Vehicle fire suppression systems Automatically detect the fire and discharges our fire suppression agents knocking the fire down in seconds.

Integrating New Technology

In today's rapidly changing world where technology is constantly evolving, machines and fuel loads are becoming larger. Increased engine compartment temperatures are making the risks much greater and the solutions more difficult . You need a partner who understands the changing hazards and can integrate new technologies into a solution that protects your operations. Amerex offers industry standard Dry Chemical systems for rapid fire knockdown, Amerex ICE liquid system for fire suppression and cooling of heated surfaces and industry best dual agent Dry-ICE combination system for the best of both worlds.

Single Release Sequence of Operation

- Fire starts In the machine releasing significant amounts of heat.
- The detectors sense the heat and send a signal to the control panel.
- The control panel interprets the signal and begins the discharge sequence activating the alarm relay for shutdowns.
- The operator may choose to activate the manual release located in the cab or at ground level at any time to begin the discharge sequence.
- The linear actuator receives the signal from the control panel and opens the cylinder valve. The fire suppression agent travels through the distribution network to the nozzles which disperse the agent.
- The fire is suppressed allowing for personnel to evacuate the machine and utilize hand held fire extinguishers or other methods if necessary.

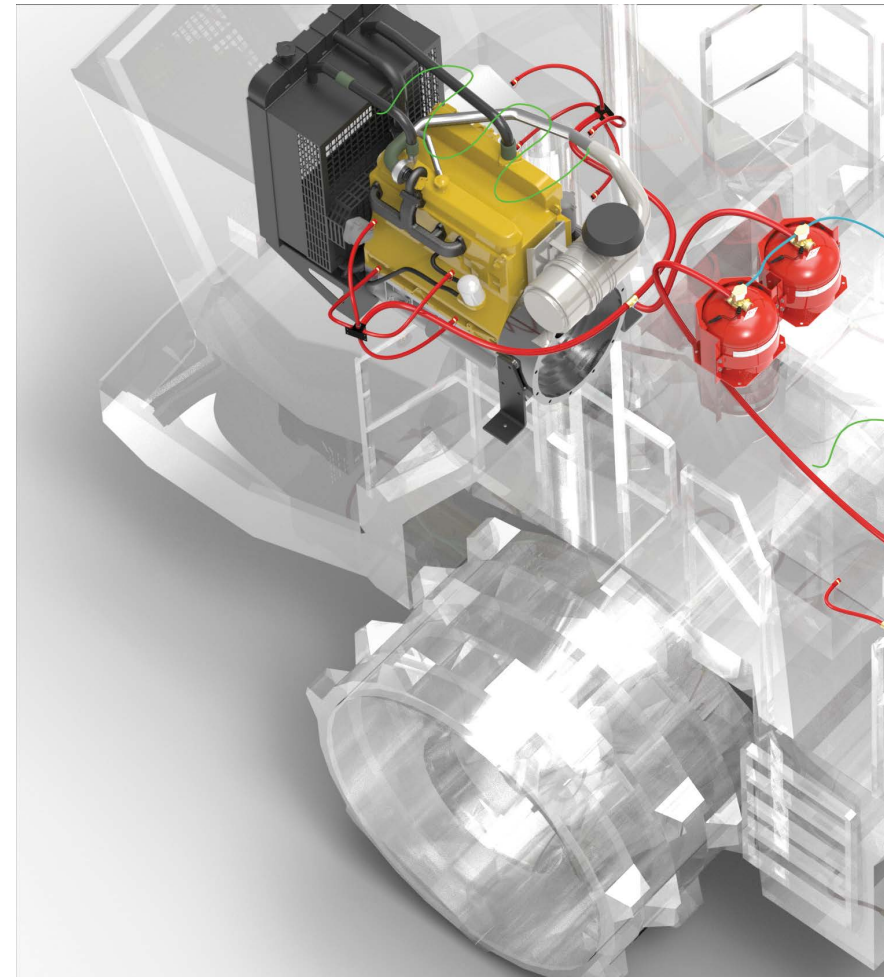

Note: The illustration shown is a conceptual and not intended to be a design drawing. A complete hazard analysis and risk assessment will have to be performed on the vehicle to determine the most probable ignition sources along with the fire characteristics and quantity of the various fuels exposed to those ignition sources. Final placement of the fire suppression components should be based on the hazard analysis and in coordination with the end user.



Amerex Vehicle Fire System Features

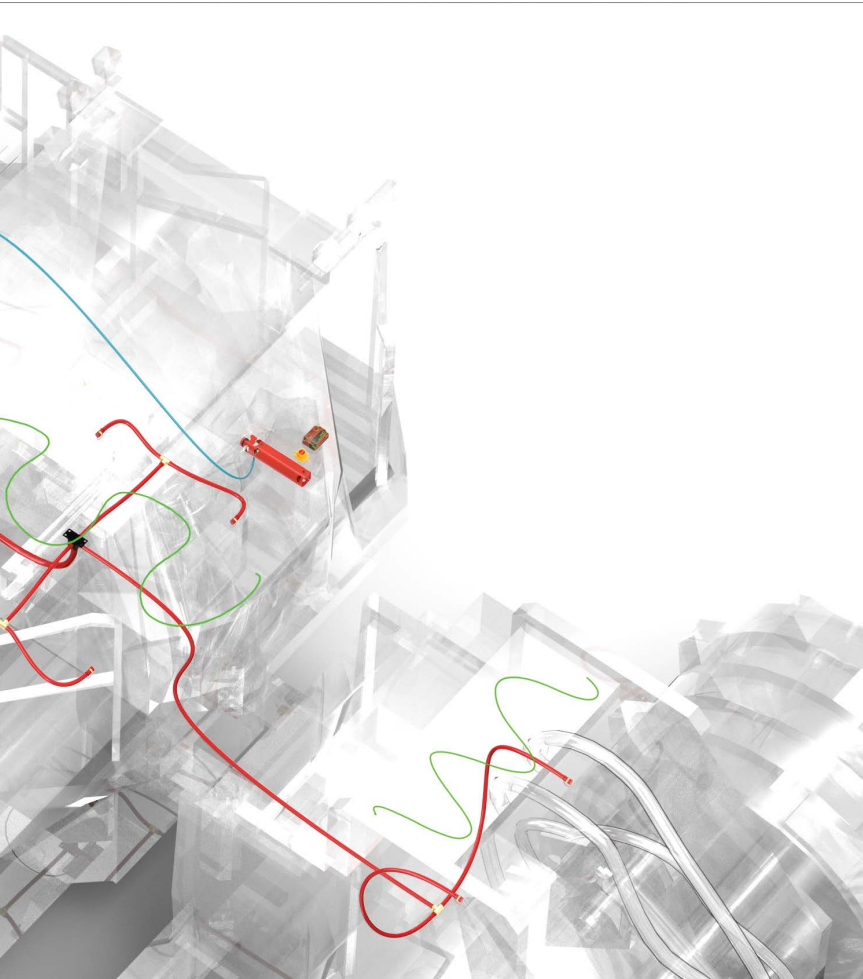

System Control Panel

The Control Panel (CP) is the “brains” of the system. The CP interprets the signal from the detection circuit, initiates the cylinder discharge, and simultaneously operates relays which can be used to stop the flow of flammable fuels.

Automatic Detection

24 hour automatic sensors rapidly detect heat from a fire and signals the CP to start the discharge sequence suppressing the fire and minimizing the damage.

Agent Cylinders

Stored pressure agent cylinders hold the suppression agent in a pressurized state, preventing agent contamination and reducing maintenance costs.

Distribution Network

Hydraulic hose or stainless steel tubing distributes the fire suppression agent to the discharge nozzles which disperse the chemical throughout the hazard area.

System Actuation

All systems have the capability to be actuated electrically, pneumatically, or as a redundant system featuring both electric and pneumatic actuation.



Dual release Sequence of Operation

- Fire starts in the machine releasing significant amounts of heat.
- The detectors sense the heat and send a signal to the control panel.
- The control panel interprets the signal and begins the discharge sequence activating the alarm relay for shutdowns.
- The operator may choose to operate the manual release located in the cab or at ground level at any time to signal the control panel and begin the discharge sequence.
- The release begins when the linear actuator receives the signal from the control panel and simultaneously opens the dry chemical cylinder and Liquid cylinder valves allowing the fire suppression agent to travel through the distribution network to the nozzles which disperse agent providing rapid fire knockdown with the dry chemical and suppression and cooling with the ICE liquid system.
- The dual release system can also be configured to provide a time delay between the dry chemical release and the ICE liquid release.
- The fire is suppressed allowing for personnel to evacuate the machine and utilize hand held fire extinguishers or other methods to extinguish the remaining fire if necessary.

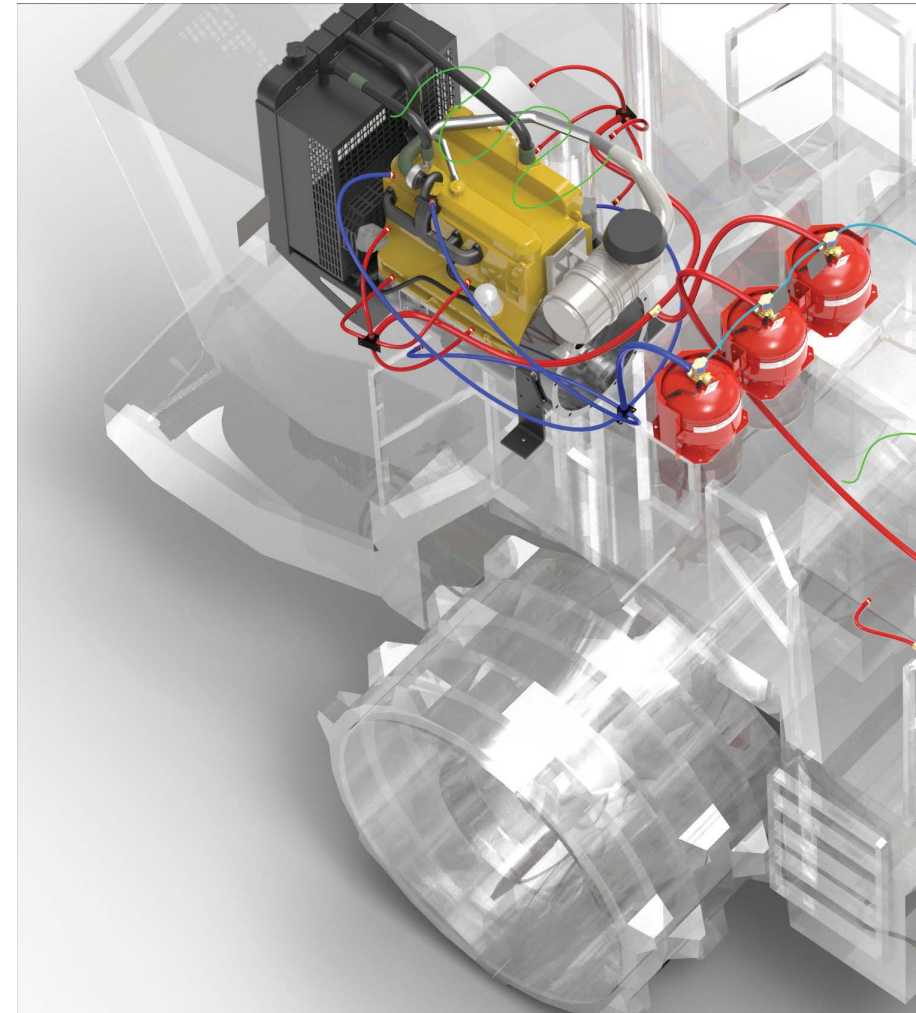

Note: The illustration shown is a conceptual and not intended to be a design drawing. A complete hazard analysis and risk assessment will have to be performed on the vehicle to determine the most probable ignition sources along with the fire characteristics and quantity of the various fuels exposed to those ignition sources. Final placement of the fire suppression components should be based on the hazard analysis and in coordination with the end user.

Amerex Vehicle Fire System Features



System Control Panel

The Control Panel (CP) is the “brains” of the system. The CP interprets the signal from the detection circuit and initiates two separate discharges of the dual agent cylinders. The CP controls relays which can be used to stop the flow of flammable fuels.

Automatic Detection

24-hour automatic heat sensors rapidly detect fire and signals the CP to start the discharge sequence suppressing the fire and minimizing the damage.

Agent Cylinders

Stored pressure cylinders hold the fire suppression agent in a state that prevents contamination thus reducing maintenance costs. The initial discharge of dry chemical agent provides for rapid fire knockdown. The second discharge of wet agent provides cooling of the heated surfaces to reduce the possibility of re-ignition.

Distribution Network

Hydraulic hose or stainless steel tubing carries the fire suppression agent to the discharge nozzles and disperses the chemical throughout the hazard area.

System Actuation

All systems have the capability to be actuated electrically, pneumatically or as a redundant system featuring both electric and pneumatic actuation.

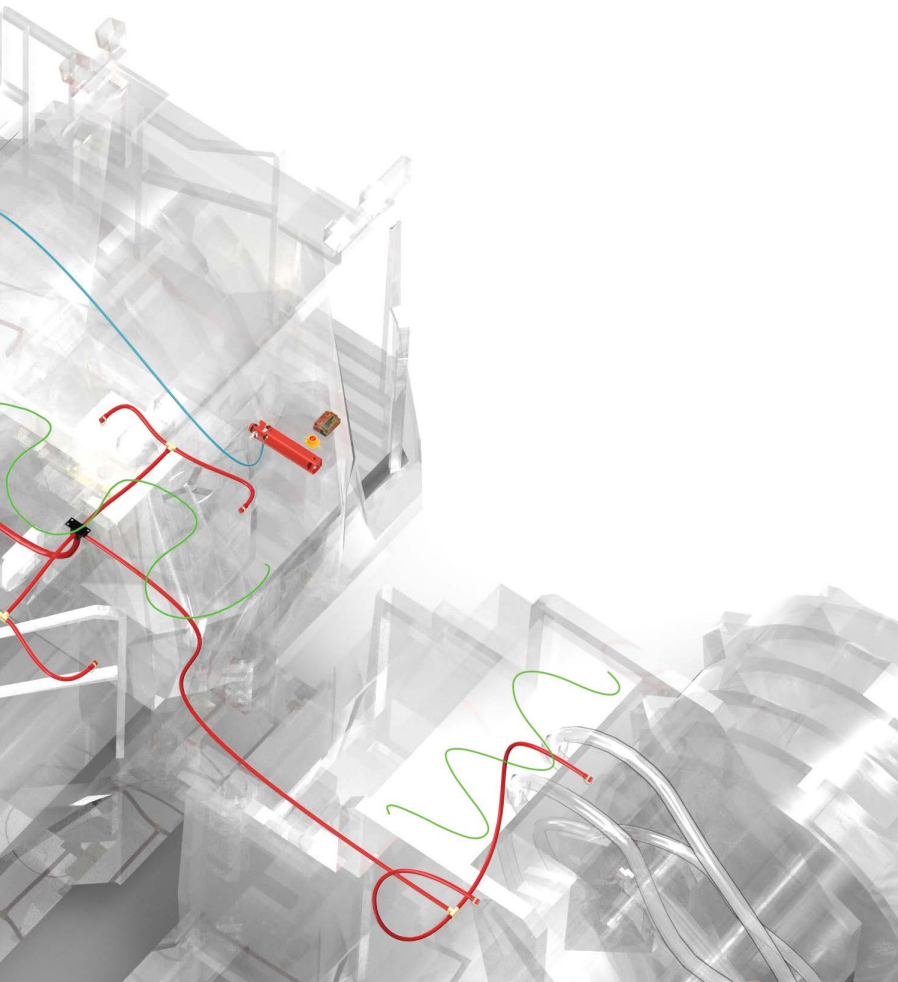

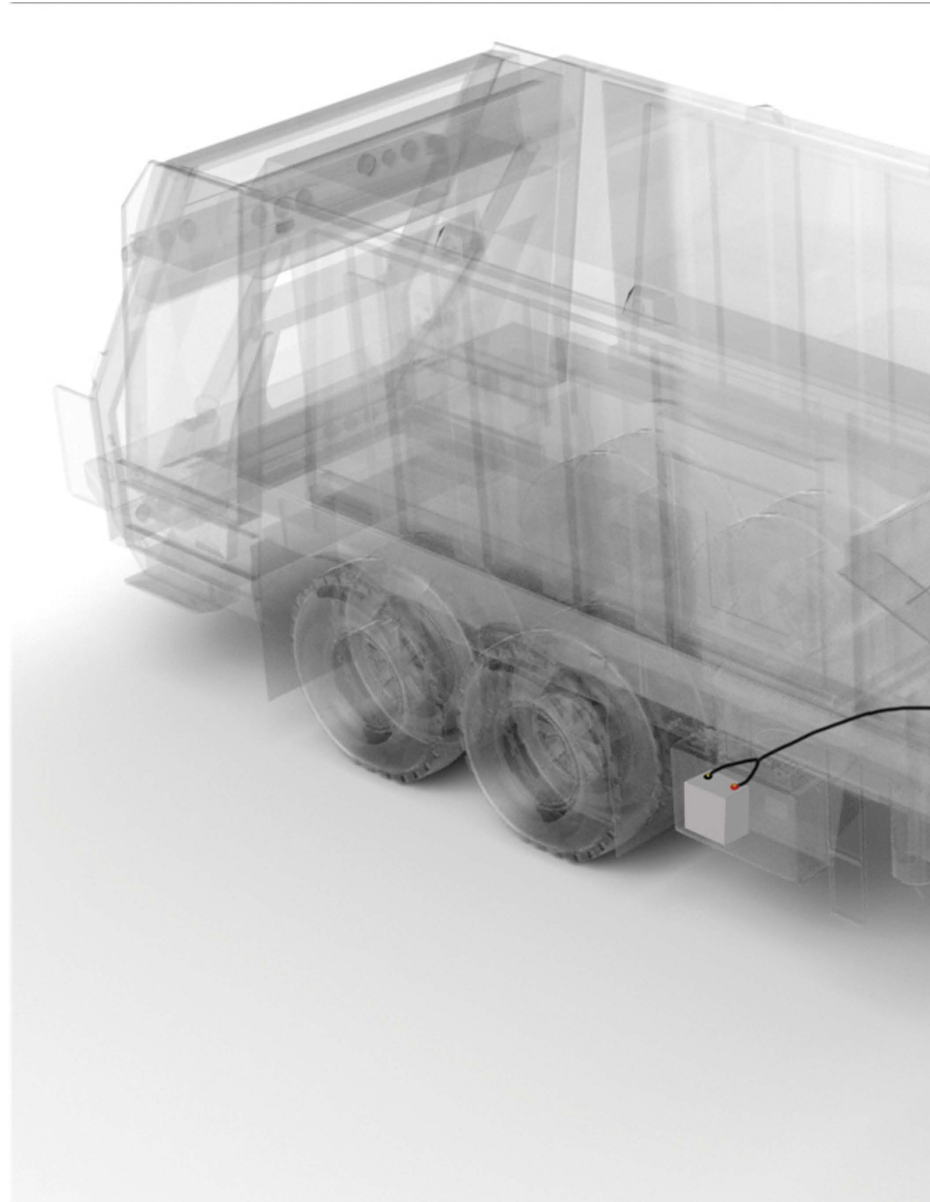

Protecting the Vehicles Protecting the Environment

- The Waste industry has taken great efforts to become more environmentally friendly and as part of that effort more and more municipal fleets are turning to alternative fueled vehicles. Protecting operators and the environment is Priority #1 which is why Amerex has developed our AMGaDS Gas Detection System.
- Developed in the early 90's more than 20,000 AMGaDS systems are in operation today.
- The AMGaDS system utilizes advanced technology for detection of propane (LPG), CNG (Compressed Natural Gas), LNG (Liquid Natural Gas), and any other hydrocarbon fuel vapors. Amerex AMGaDS Gas Detection System provides you with the piece of mind.

Note: The illustration shown is a conceptual and not intended to be a design drawing. A complete hazard analysis and risk assessment will have to be performed on the vehicle to determine the most probable ignition sources along with the fire characteristics and quantity of the various fuels exposed to those ignition sources. Final placement of the fire suppression components should be based on the hazard analysis and in coordination with the end user.

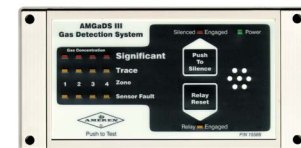

AMGaDS Gas Detection System Features

System Control Panels

The Control Panel (CP) is the “brains” of the system. The CP interprets the signal from the Gas Sensors, initiates Trace or Significant gas alarm conditions to notify the operator and simultaneously operates relays which can be used to stop the flow of Explosive fuels.

Gas Sensors

24 hour automatic sensors rapidly detect the presence of combustible gases and sends a “Trace Fault” signal to the control panel when the concentration of gas reaches 20% of the LEL (Lower Explosive Limit) and sends a “Significant Alarm” signal when the concentration reaches 50% of the LEL.

Wiring Harness

All wiring harnesses connectors for the AMGaDS system are pre-terminated at the factory for quality assurance and ease of installation. The “plug and play” cables are available in a wide range of sizes to meet your specific need.

Gas Sensor Sequence of Operation

- A combustible gas leak occurs on the vehicle
- The detectors sense the concentration of explosive gas and sends a signal to the control panel.
- The control panel alerts the operator by audio and visual signal to the gas leak condition.
- If the concentration reaches the “significant” alarm level (50% of the LEL) the control panel goes into alarm and activates the alarm relay for shutdowns.
- The operator can bring the vehicle to a safe stop and investigate the source of the alarm.





Dry Chemical Systems

Dry Chemical systems provide the fastest fire knockdown of any available agent. The properties of the dry chemical allows it to flow around obstructions reaching the hidden areas in the engine compartment.

Liquid Systems

Amerex ICE liquid systems are FM approved for suppression on mobile equipment. The ICE system combines fire suppression capabilities and the added benefit of cooling. The ICE agent is effective on class A materials and by reducing the temperatures of the heated surfaces will significantly reduce the chance for the fire to re-flash.



Amerex Dry ICE

Amerex combines the best of both Dry Chemical and our ICE liquid system to provide the industries best protection for your Operator, Equipment and the Environment.



The safest decision you will ever make

We know that you have a lot of choices. We also know the importance of fire suppression to your business. We are committed to providing the best possible fire solution and it shows in our innovation, quality and commitment to service. Amerex has been providing fire fighting products since 1971. We are the worldwide leader in hand portable and wheeled fire extinguishers. Our product line also includes gas detection, industrial, kitchen and clean agent systems.

Amerex products are proudly MADE IN THE USA!

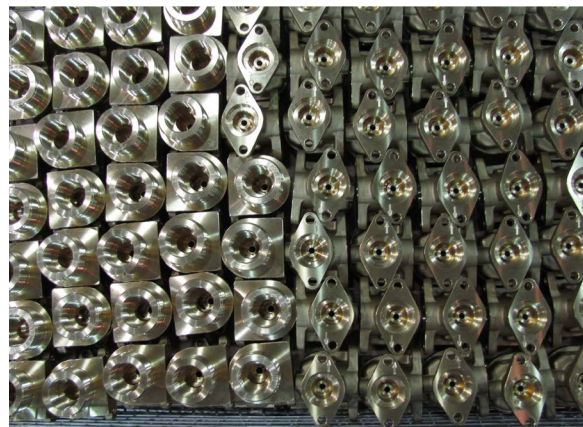
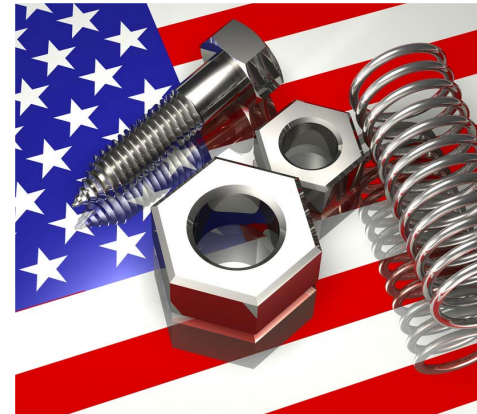
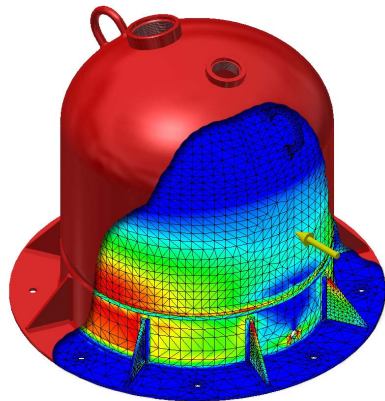



Quality is Behind the Diamond.

Amerex Corporation

Post Office Box 81

7595 Gadsden Highway

Trussville, AL 35173-0081 U.S.A.

Phone 205.655.3271

Fax 800.654.5980 (USA)

205.655.0854 (Int'l)

sales@amerex-fire.com

www.amerex-fire.com

Internationally recognized ISO 9001 and ISO 14001 registered firm

© 2014 Amerex Corporation

Part No.: SL-1820 04/2014