



KODIAK 
FIERCE VEHICLE FIRE PROTECTION



Quality is Behind the Diamond

The *KODIAK* Advantage - *Quality • Experienced Innovation • Made in the USA*



Because it Absolutely Matters

Amerex vehicle fire suppression systems are manufactured at our facility in Trussville, Alabama and meet the requirements of the “Buy America Act”. Our products are made in the USA so we can provide you with the quality and flexibility your operation demands - when you need it most.

Quality without Compromise and Experienced Innovation

The best mining operations are uncompromising when it comes to the quality and reliability of their vehicles. At Amerex, we believe the same should be true when it comes to protecting those investments from debilitating fires and loss of production. With the experience of over 100,000 fire suppression systems sold, the Amerex vehicle fire suppression team has developed the most innovative fire suppression systems in the industry. The *KODIAK* Fire Suppression Systems provide *Fast and Fierce Fire Protection*.

Why Amerex?

- **Quality** Manufactured in the USA, we provide higher quality products and ship them to you quickly
- **Experience** At Amerex, we use our experience to develop programs focused on understanding the mining industry and implementing processes of continuous improvement
- **Innovation** Our dedicated vehicle systems engineering team uses advancements in technology to develop customized solutions for mining industry challenges



Quality is Behind the Diamond

The *KODIAK* Advantage - Stored Pressure Agent Cylinders



Dry Agent Cylinders

Dry - ICE Cylinders

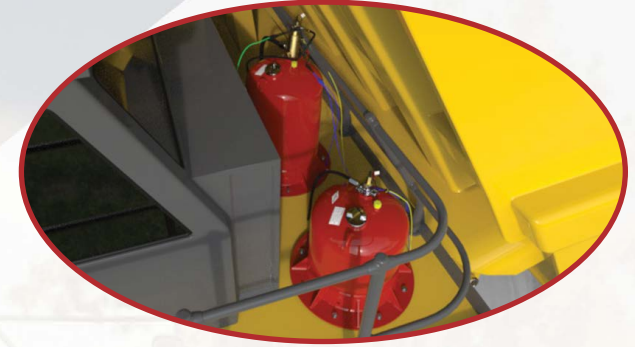

ICE Liquid Agent Cylinders



Why Stored Pressure?

- Prevents moisture from entering the cylinder and contamination of the fire suppression agent
- Agent is fluidized and ready to go when needed; no need for delays while the cylinder is being pressurized from an outside source
- Stored pressure cylinders have a pressure gauge which allows maintenance personnel to verify readiness
- Stored pressure cylinders can also be fitted with a pressure switch which detects a low pressure condition and notifies the operator via the control panel

Vehicles are different, and so are the protection agent options

We know that all vehicle hazards are not the same, so we offer three different suppression agent options to protect your vehicle.

- **Dry Agent Systems** - provide the fastest fire knockdown as well as getting into those hard to reach areas where fire may hide.
- **ICE Liquid Agent Chemical** - Provides suppression and cooling of heated surfaces to help prevent a fire from reigniting.
- **Amerex Dry-ICE Systems** - Combines the strengths of both agents and provides the best possible fire protection option by providing rapid fire knockdown with dry agent and the cooling effects of the ICE liquid agent system.

Fast Fact

Cartridge operated agent cylinders require semi-annual inspection. National Fire Protection Association (NFPA) Standard 17 states: "If there is evidence of caking the dry chemical shall be discarded". "Dry chemical stored pressure cylinders shall not require semi-annual examination but shall require examination at least every 6 years".

The *KODIAK* Advantage - Control Panel Options



Features of the 17 Series panel

- Single detection and releasing zone
- 24 hour protection with battery backup diagnostic flash code for easy troubleshooting
- Programmable discharge and alarm relays



Features of the SafetyNet panel

- Full network ability to add additional detection and releasing zones
- 4000 event log - time and date stamped, down loadable log for easy troubleshooting and incident investigation
- AMT—Automatic Maintenance Testing mode to significantly reduce maintenance time
- Supports natural gas detection and infrared flame detectors for combination fire and natural gas detection systems



Features of the SA2Z panel

- Two independent detection and releasing zones
- Self contained battery power supply with no power drain on the vehicle
- 100 event log with time and date stamped for easy troubleshooting and incident investigation
- Integrated manual release on panel

Fast Fact

Event logs can be downloaded and provided to the vehicle owner to verify testing has been completed and kept as part of that units permanent record.



Quality is Behind the Diamond



The *KODIAK* Advantage - *Fire Detection Options*



Linear Heat Detection cables have long been the industry standard and provide a continuous heat detection cable run inside the hazard area. The *Kodiak* Advantage has amped up the traditional cable with a more robust abrasion resistant outer jacket and factory installed connectors for reliability and ease of service. The cable is also available with a stainless steel wire protective covering for extreme environments.

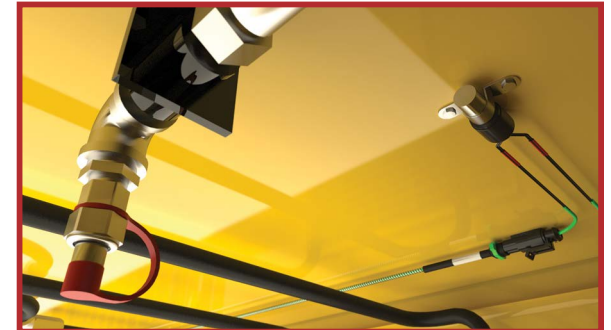

Spot Heat Detectors are available in three different preset temperature settings for flexibility and provide rapid heat detection and system activation. Spot Heat Detectors have factory installed connectors for reliability and ease of installation and service.

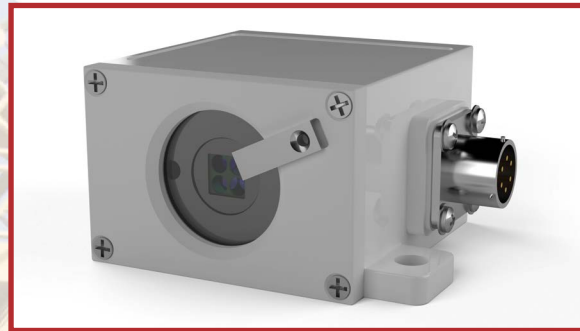

The Kodiak IR3 Infrared Detector is the fastest responding detector in the industry, responding to fire within seconds. Faster response means less damage and less downtime. IR3 detectors “see” the fire by recognizing the light wavelength patterns thrown off by the hydrocarbon fire.

Fast Fact

Multiple types of detectors can be used on the same vehicle to provide faster response in high risk areas.

The KODIAK Advantage - ICE Liquid Agent Systems

Amerex ICE suppression system

- Amerex ICE System is an FM Approved, pre-engineered fire suppression and cooling system designed specifically for protection of vehicles
- Each system uses vertical and horizontal stored pressure agent cylinders discharging ICE agent to predetermined nozzle flow rates
- The ICE system works by blanketing liquid fuel surfaces preventing oxygen from combining with ignition sources and fuel
- Each system provides cooling of heated surfaces to reduce the chances of a fire re-ignition
- Each system can operate within temperature ranges from -40F to 120F (-40C to 49C)

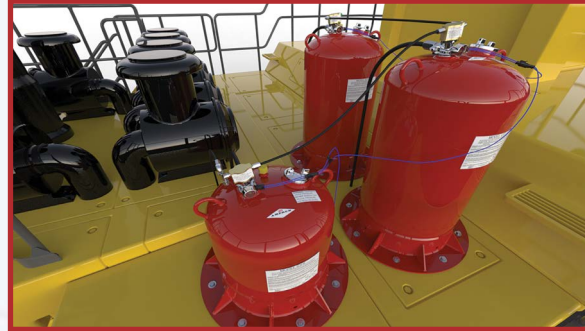

Agent Cylinders



Detection Network

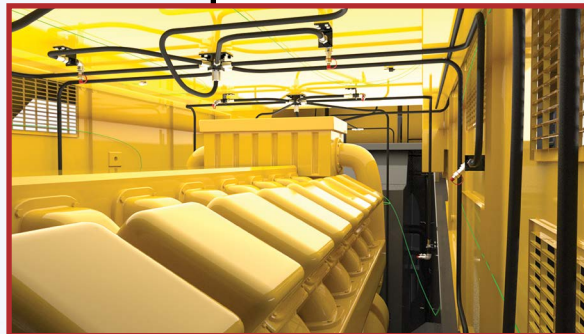

ICE Nozzles

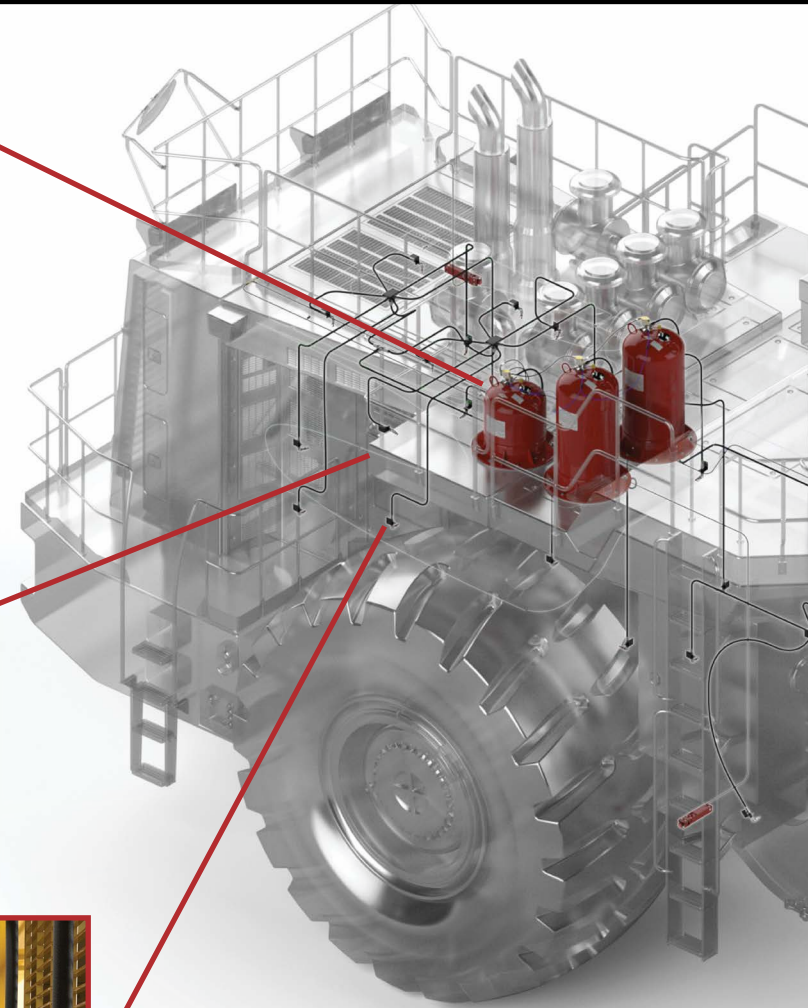

Fast Fact

ICE liquid agent significantly reduces clean up time after a discharge by containing the agent to the hazard area.



Quality is Behind the Diamond

The KODIAK Advantage - ICE Liquid Agent Systems



17 Series Panel



High Flow Extinguisher



Fast Fact

The Amerex ICE system is also highly effective on cooling and wetting ordinary combustible Class A materials.



Manual Actuator



The *KODIAK* Advantage - *Dry-ICE* Dual Agent Systems

Amerex Dry-ICE dual agent suppression system

- Amerex Dry-ICE System provides the best possible fire protection option by combining the rapid knockdown power of dry agent with the cooling effect of ICE liquid agent
- The dual agent is designed for simultaneous discharge or with a time delay between Dry and ICE release for an extended discharge for larger vehicles
- The Dry-ICE system meets the dual agent requirement of NFPA 122 12.3.6.1.1 for hydraulic/diesel excavators with hydraulic systems larger than 150 gallons



SAZZ Panel



Detection Network



Manual Actuator

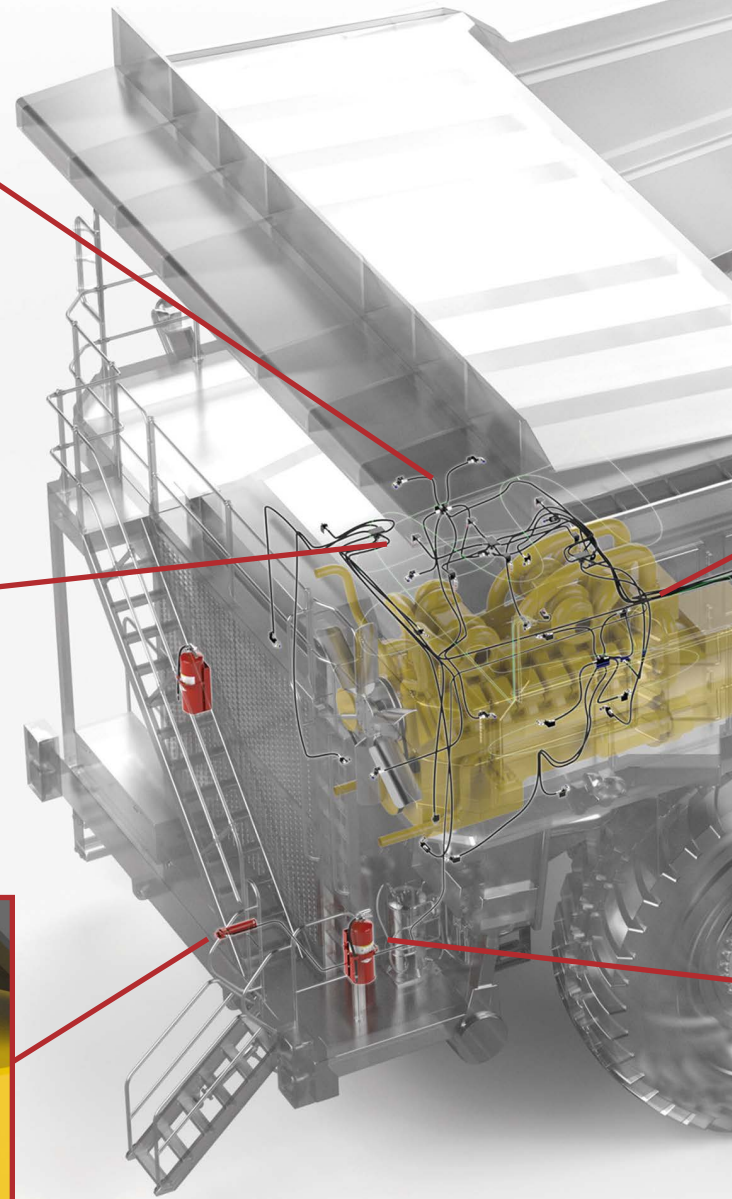

Fast Fact

Amerex control panels have programmable discharge delays from 0-15 seconds in 5 second increments.



Quality is Behind the Diamond

The *KODIAK* Advantage - *Dry-ICE Dual Agent Systems*

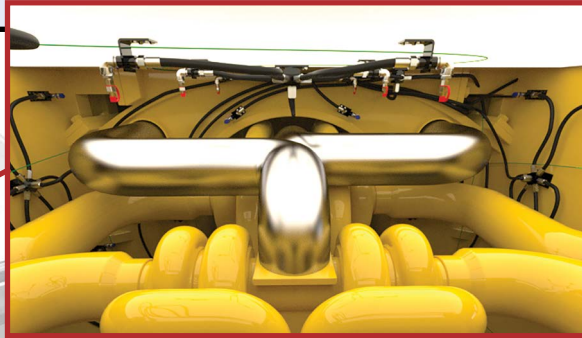

Engine Compartment

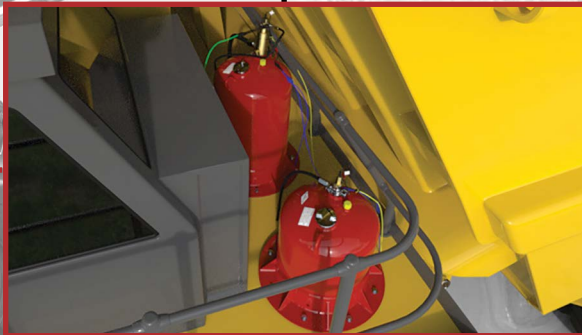

Cylinders



High Flow Extinguisher



Fast Fact

Fires on mining equipment with large volumes of hydraulics and diesel fuels can reignite after a fire is suppressed if the flammable fuel is not shut off, or the ignition sources aren't cooled.



Innovations In Technology

Natural Gas Detection and Fire Suppression Systems

SafetyNet

Fire Suppression and Natural Gas Detection

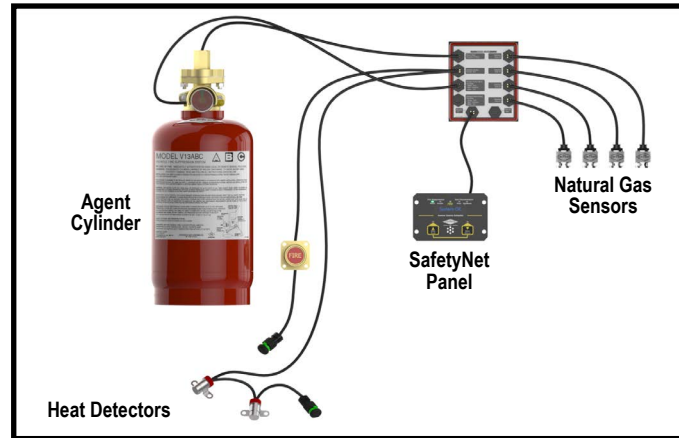

AMGaDS IV Natural Gas Detection System

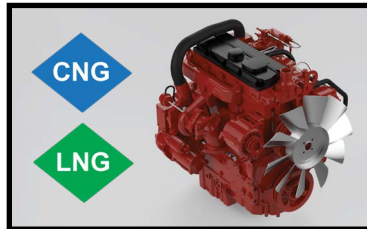
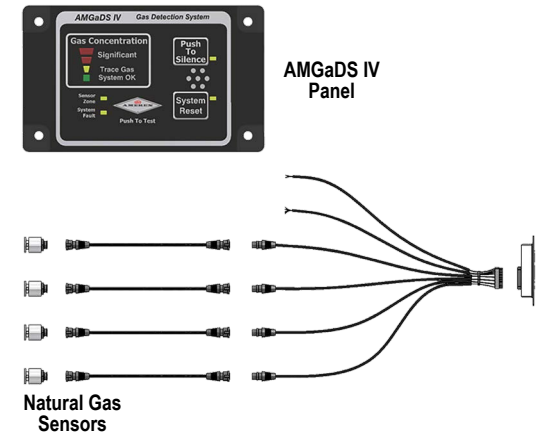

Natural Gas Engine



Natural Gas Sensor

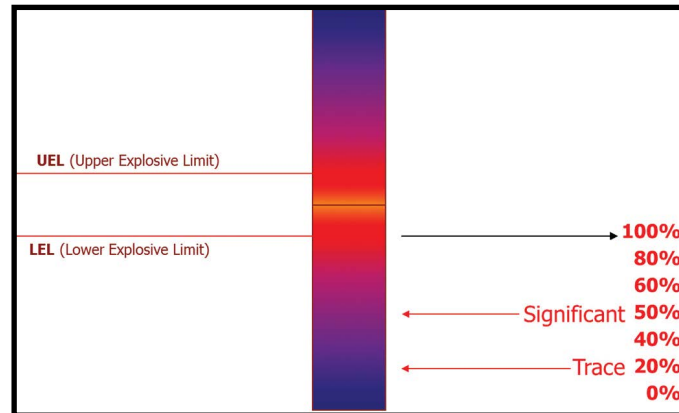

The Future of Mining includes *High Horsepower Natural Gas Engines*. Amerex has been the leader in natural gas vehicle detection for over 20 years. The AMGaDS IV system provides gas detection to notify the Operator of a gas leak. The Amerex SafetyNet system provides both gas detection and fire suppression capabilities





Quality is Behind the Diamond

AMEREX CORPORATION
www.amerex-fire.com
sales@amerex-fire.com
+1 205 655 3271

P.O. Box 81
7595 Gadsden Highway
Trussville, AL 35172-0081 U.S.A.

© 2018 Amerex Corporation internationally recognized
ISO 9001 and ISO 14001 registered firm

Part No: SL-121